

Material Handling Machine

LH 110 Industry

Litronic®

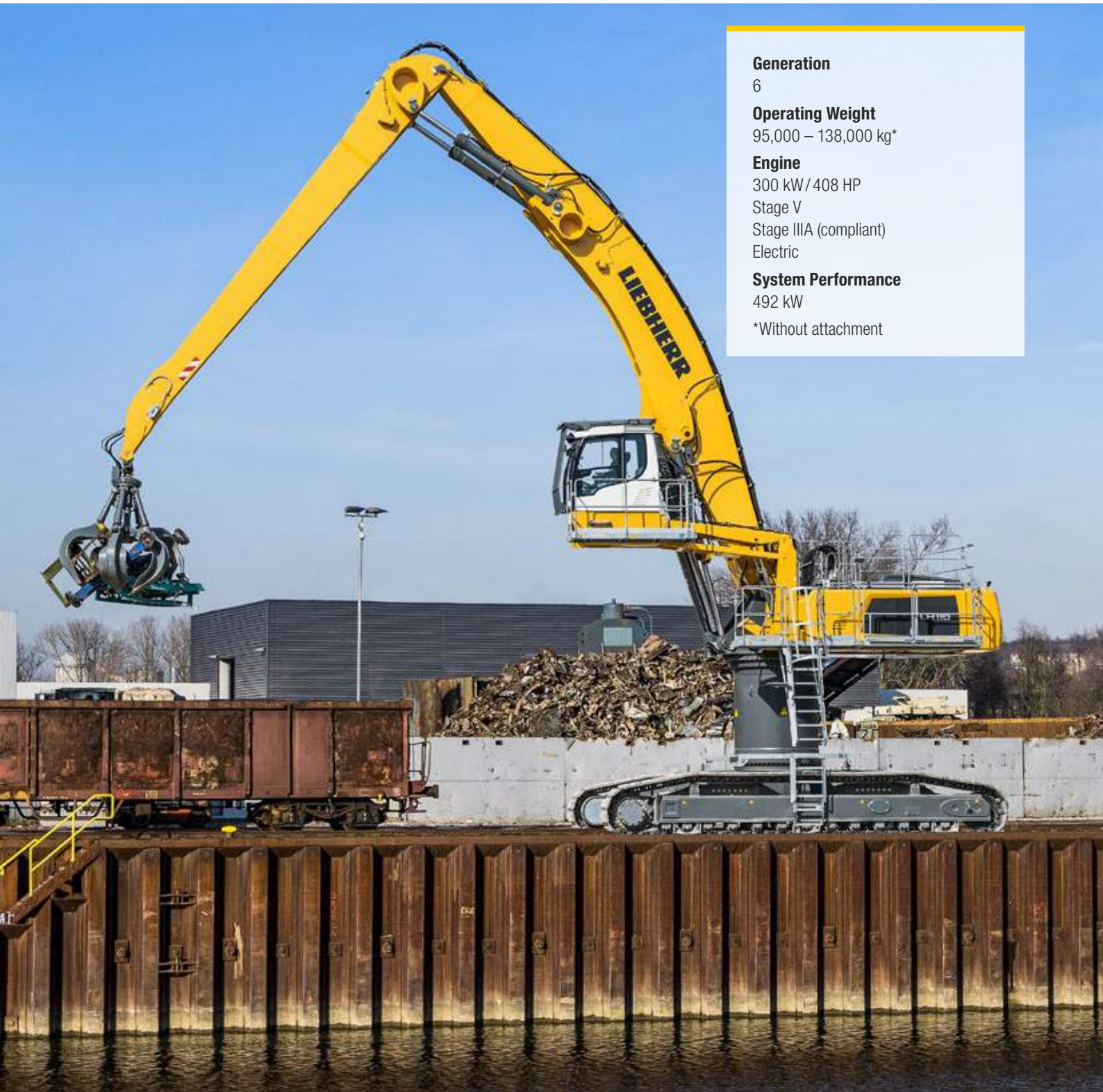

Generation

6

Operating Weight

95,000 – 138,000 kg*

Engine

300 kW / 408 HP

Stage V

Stage IIIA (compliant)

Electric

System Performance

492 kW

*Without attachment

LIEBHERR

Material Handling Machines Overview

Uppercarriage

- 2-circuit Liebherr-Synchron-Comfort-system (LSC) with LUDV technology for faster working speed at minimum fuel consumption
- 300 kW engine output and high pump flow for fast work cycles, convincing dynamics and maximum handling performance
- Electrical pilot control enables individual settings for the operator and new options such as load torque limitation
- Reduction in operating costs thanks to built-in maintenance advantages and optimum service accessibility
- Optimised hydraulics with closed slewing mechanism circuit for greater fuel efficiency and faster work cycles

Undercarriage

- Central lubrication system manually centralised or automatically for more productive working time at mobile undercarriage
- Large footprint for high stability and maximum lift capacities
- Variety of undercarriage options for different applications available
- Low service costs due to travel drive without gearbox and cardan shafts on mobile undercarriage





Equipment

- Designed for use in tough scrap recycling with high-strength steel plates at high-stress areas for maximum service life
- Energy recovery cylinder filled with nitrogen for maximum efficiency through less fuel consumption at more handling capacity
- Pipe fracture safety valves on hoist and stick cylinders and retract stick shut-off for maximum safety during every application
- Electro-hydraulic end position control extends the service life of the components
- Quick coupling systems and attachments made by Liebherr for maximum machine capacity, utilisation and greater handling performance

Operator's Cab

- Hydraulic cab elevations provide the best view downwards as well as forwards
- Lower noise emissions for less strain on the operator, workers and reduced environmental pollution
- Optimum visibility thanks to large glass surfaces and standard rear and side camera monitoring
- Joystick steering without steering column as standard for convenient operation, greater legroom and clear view of the working area at mobile undercarriage
- Proportional control as standard with 4-way mini joystick for greater precision, highprecision control and functions

The Perfect Solution for Every Application

Attachments



Multi-tine grab

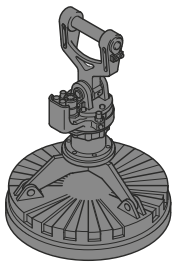

Magnet devices

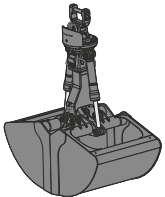

Shells for loose material



Wood grab

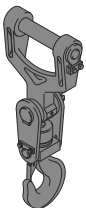

Load hook

Sticks

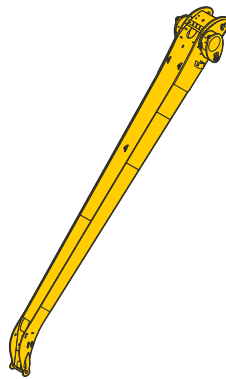

Angled stick

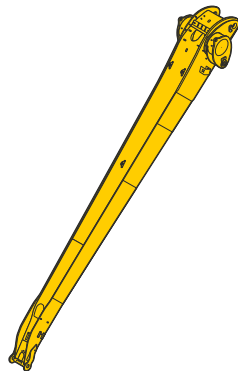

Straight stick

Booms

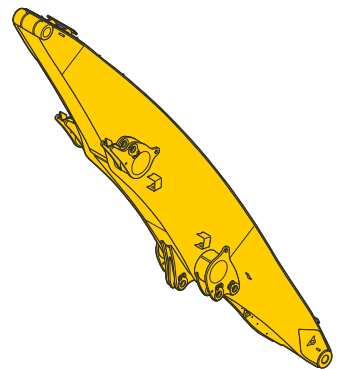

Straight boom

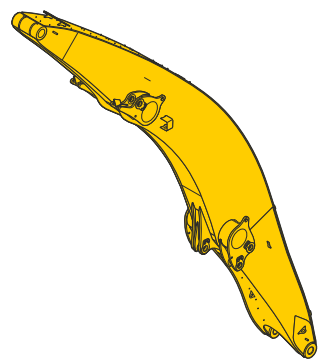

Angled boom

Cab Elevations

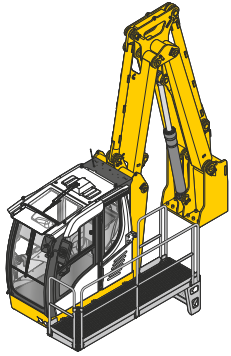

Hydraulic cab elevation

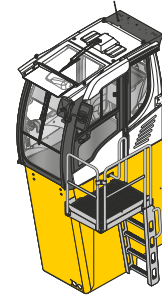
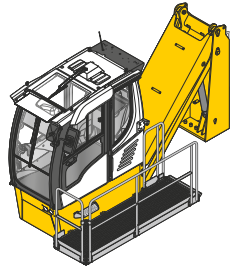

Rigid cab elevation

Uppercarriage

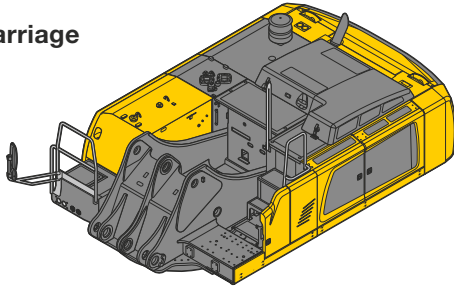

Diesel engine

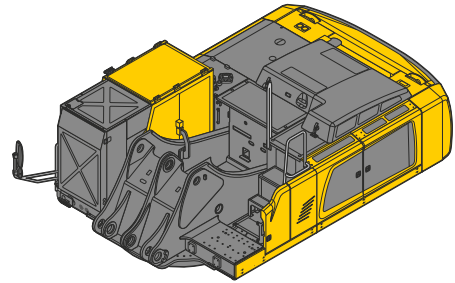

Electric motor

Undercarriage



Turret Elevations

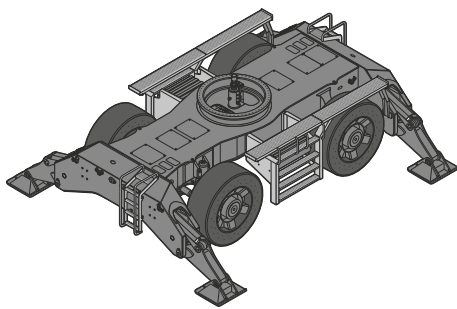

Mobile

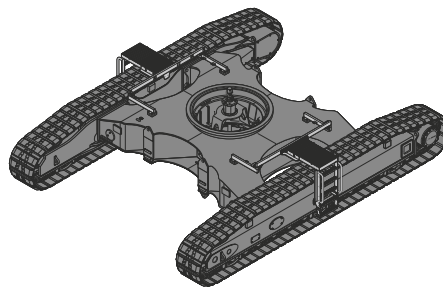

Crawler

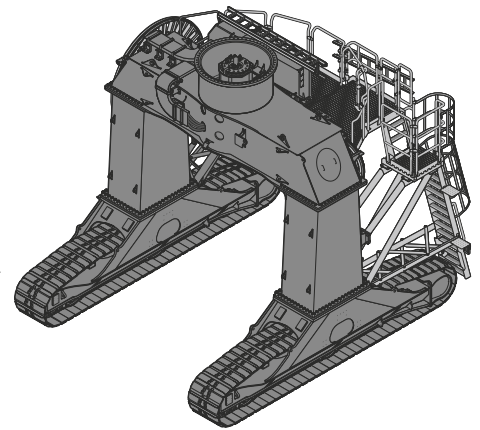

Gantry (Crawler/Track)

Technical Data



Diesel Engine

Rating per ISO 9249	300 kW (408 HP) at 1,800 RPM
Model	Liebherr D946
Type	6 cylinder in-line
Bore/Stroke	130/150 mm
Displacement	11.95 l
Engine operation	4-stroke diesel Common-Rail turbo-charged and after-cooled reduced emissions
Air cleaner	dry-type air cleaner with pre-cleaner, primary and safety elements
Engine idling	sensor controlled
Electrical system	
Voltage	24 V
Batteries	2 x 180 Ah/12 V
Alternator	three-phase current 28 V/140 A
Stage V	
Harmful emissions values	according to regulation (EU) 2016/1628
Emission control	Liebherr-SCRFilter technology
Fuel tank	1,350 l
Urea tank	180 l
Stage IIIA (compliant)	
Harmful emissions values	in accordance with ECE-R.96 Power Band H
Fuel tank	1,350 l



Electric Motor

Rating	300 kW at 1,700 RPM
Model	Liebherr KGF1182/6
Type	three-phase squirrel cage motor
Secondary electric motor	
Electric motor auxiliary equipment (air-conditioning compressor, alternator 24 V)	15 kW
Electrical system energy supply	Liebherr drive components and control cabinets for uppercarriage and undercarriage Liebherr frequency converter fed drive system heavy-duty version
Manufacturer	Liebherr
Supply voltage	
Low voltage	380 – 690 V
High voltage	2.14 – 20 kV
Frequency	50/60 Hz
Engine idling	sensor controlled
Electrical system	battery-assisted control system, lighting, diagnostics system
Voltage	24 V
Batteries	2 x 180 Ah/12 V
Alternator	three-phase current 28 V/140 A



Cooling System

Diesel engine	water-cooled cooling system, consisting of a cooling unit for water and charge air and a 2 nd cooler for hydraulic oil, each with an infinitely variable, thermostatically controlled fan drive system
Electric motor	air-cooled cooling system for hydraulic oil with an infinitely variable, thermostatically controlled fan drive system frequency converter water-cooled



Hydraulic Controls

Power distribution	via control valves with integrated safety valves, simultaneous actuation of chassis and equipment. Swing drive in separate closed circuit
Servo circuit	
Equipment and swing	with electro-hydraulic pilot control and proportional joystick levers
Chassis	with electric proportionally functioning foot pedals or adjusted with plugable levers via switch or electroproportional foot pedals
Additional functions	
Proportional control	proportionally acting transmitters on the joysticks for additional hydraulic functions



Hydraulic System

Hydraulic pump	
for equipment and travel drive	2 Liebherr axial piston variable displacement pumps (double construction)
Max. flow	2 x 462 l/min.
Max. pressure	350 bar
for swing drive	reversible axial piston variable displacement pump, closed-loop circuit
Max. flow	355 l/min.
Max. pressure	345 bar
Hydraulic pump regulation and control	2 circuit Liebherr-Synchron-Comfort-system (LSC) with electronic engine speed sensing regulation, pressure and flow compensation, automatic oil flow optimizer
Hydraulic tank	455 l
Hydraulic system	1,175 l
Hydraulic oil filter	2 main return filters with integrated partial micro filtration (5 µm)
MODE selection	adjustment of engine and hydraulic performance via a mode pre-selector to match application, e.g. for especially economical and environmentally friendly operation or for maximum material handling and heavy-duty jobs
S (Sensitive)	mode for precision work and lifting through very sensitive movements
E (Eco)	mode for especially economical and environmentally friendly operation
P (Power)	mode for high performance with low fuel consumption
P+ (Power-Plus)	mode for highest performance and for very heavy duty applications, suitable for continuous operation
Engine speed and performance setting	stepless alignment of engine output and hydraulic power via engine speed
Option	Tool Control: 20 preadjustable pump flows and pressures for add-on attachments



Swing Drive

Drive	Liebherr axial piston motor in a closed system, Liebherr planetary reduction gear
Swing ring	Liebherr, sealed race ball bearing swing ring, internal teeth
Swing speed	0 – 6.5 RPM stepless
Swing torque	200 kNm
Holding brake	wet multi-disc (spring applied, pressure released)
Option	slewing gear brake Comfort



Operator's Cab

Cab	safety cab structure with fixed built-in front and roof window made from impact-resistant laminated safety glass, work headlights integrated in the ceiling, a door with a sliding window (can be opened on both sides), large stowing and depositing possibilities, shock-absorbing suspension, sounddamping insulating, tinted laminated safety glass, separate shades for the sunroof window and windscreen
High Rise/Gantry	deviating from standard: safety cab structure with fixed built-in front and roof window made from impact-resistant laminated safety glass
Operator's seat Comfort	air cushioned operator's seat with 3D-adjustable armrests, headrest, lap belt, seat heater, adjustable seat cushion inclination and length, lockable horizontal suspension, automatic weight adjustment, adjustable suspension stiffness, pneumatic lumbar vertebrae support and passive seat climatization with active coal
Operator's seat Premium (Option)	in addition to operator's seat comfort: active electronic weight adjustment (automatic re-adjustment), pneumatic low frequency suspension and active seat climatization with active coal and ventilator
Control system	joysticks with control consoles and swivel seat, folding left control console
Operation and displays	large high-resolution operating unit, self-explanatory, colour display with touchscreen, video-compatible, numerous setting, control and monitoring options, e.g. air conditioning control, fuel consumption respectively energy consumption, machine and attachment parameters
Air-conditioning	
Diesel engine	automatic air-conditioning, recirculated air function, fast de-icing and demisting at the press of a button, air vents can be operated via a menu; recirculated air and fresh air filters can be easily replaced and are accessible from the outside; heating-cooling unit, designed for extreme outside temperatures, sensors for solar radiation, inside and outside temperatures
Electric motor	in addition to diesel engine: stationary air conditioning function with external climate condenser – controlled by a weekly timer
Refrigerant	R134a
Global warming potential	1,430
Quantity at 25 °C*	1,500 – 2.000 g
CO ₂ equivalent*	2.145 – 2.86 t
Vibration emission**	
Hand/arm vibrations	< 2.5 m/s ²
Whole-body vibrations	< 0.5 m/s ²
Measuring inaccuracy	according with standard EN 12096:1997

* depending on configuration

** for risk assessment according to 2002/44/EC see ISO/TR 25398:2006



Undercarriage

Mobile	
Versions	Standard, High Rise
Drive	one driven axle with transmission with Liebherr axial piston motor and functional brake valve on both sides
Travel speed	
Joystick steering	0 – 5.0 km/h stepless (creeper speed) 0 – 8.0 km/h stepless
Driving operation	automotive driving using accelerator pedal, cruise control function: storage of variable accelerator pedal positions
Axles	90 t drive axles; manual or automatic hydraulically controlled front axle oscillation lock
Service brake	two circuit travel brake system with accumulator; wet and backlash-free disc brake
Holding brake	wet multi-disc (spring applied, pressure released)
Stabilization	4 point outriggers
Crawler	
Versions	SW, High Rise, Gantry
Drive	Liebherr compact planetary reduction gear with Liebherr axial piston motor per side of undercarriage
Travel speed	0 – 2.6 km/h stepless (creeper speed) 0 – 4.0 km/h stepless
Brake	functional brake valves on both sides
Holding brake	wet multi-disc (spring applied, pressure released)
Track pads	flat
Tracks	sealed and greased



Equipment

Type	high-strength steel plates at highly stressed points for the toughest requirements. Complex and stable mountings of equipment and cylinders
Hydraulic cylinders	Liebherr cylinders with special sealing and guide system and, depending on cylinder type, shock absorption
Energy recovering cylinder	Liebherr gas cylinder with special sealing and control system
Bearings	sealed, low maintenance



Complete Machine

Lubrication	Liebherr central lubrication system for upper-carriage and equipment, automatically
Mobile (Option)	Liebherr central lubrication system for under-carriage, automatically
Steps system	safe and durable access system with anti-slip steps; main components hot-galvanised
Noise emission	
ISO 6396	L _{pA} (inside cab) = 70 dB(A) (Stage V)
2000/14/EC	L _{WA} (surround noise) = 107 dB(A) (Stage V)
ISO 6396	L _{pA} (inside cab) = 70 dB(A) (Stage IIIA compliant)
2000/14/EC	L _{WA} (surround noise) = 107 dB(A) (Stage IIIA compliant)
ISO 6396	L _{pA} (inside cab) = not specified (Electric)
2000/14/EC	L _{WA} (surround noise) = not specified (Electric)

LH 110 M – Dimensions

Industry

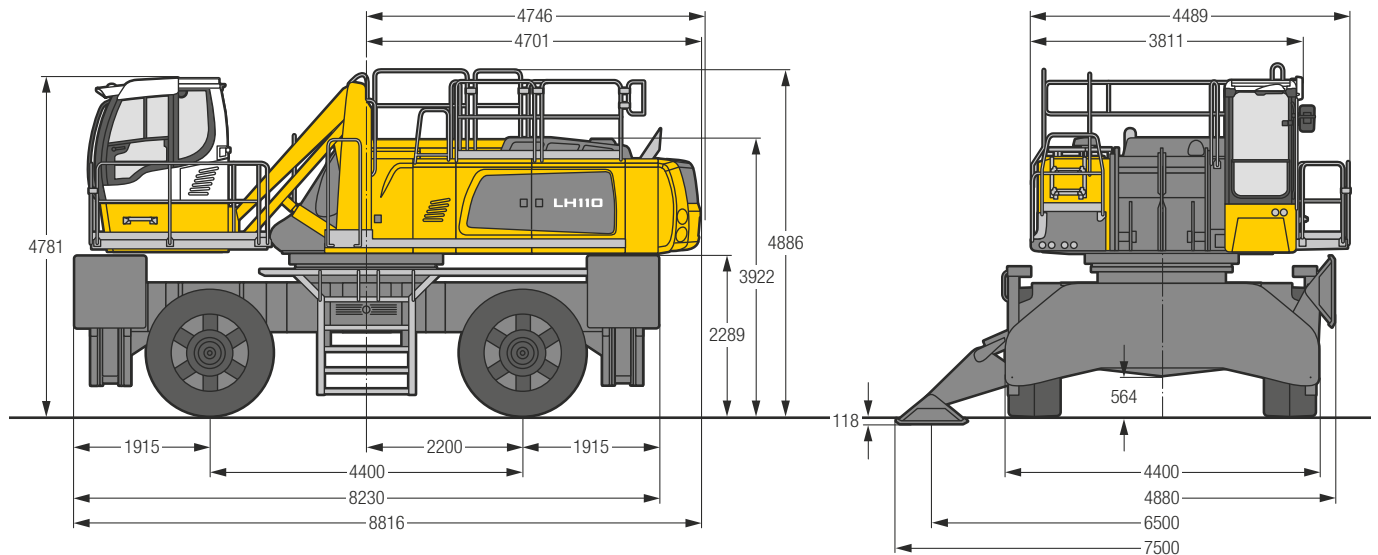

LH 110 M – Cab Elevation

Cab Elevation LHC (Hydraulic Elevation)

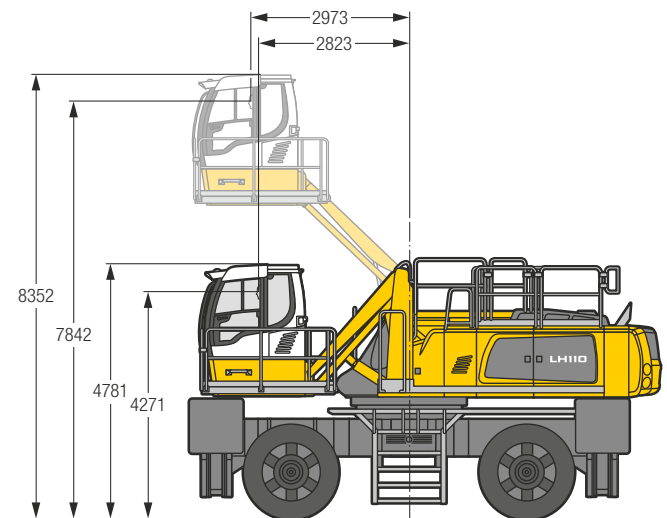

Increase type **LHC 360-50**
 The hydraulically adjustable cab allows the driver, that he can choose his field of view freely and at any time within the stroke.

Tyres 26.5-66

LH 110 M HR – Dimensions

Industry

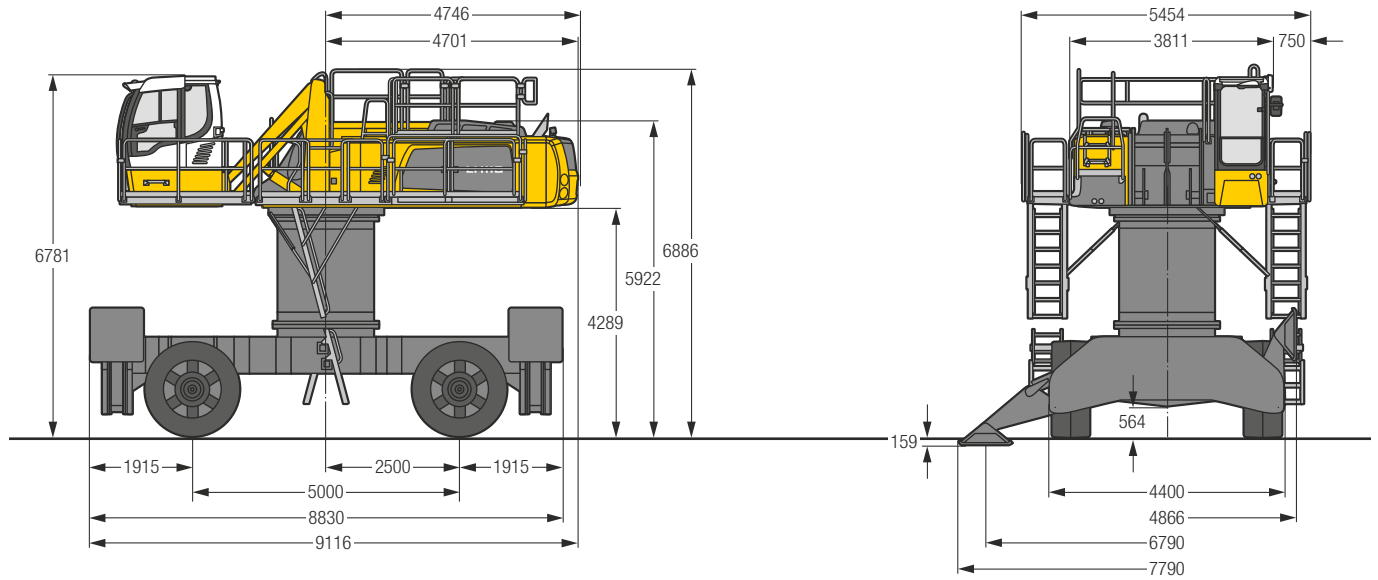

LH 110 M HR – Cab Elevation

Cab Elevation LHC (Hydraulic Elevation)

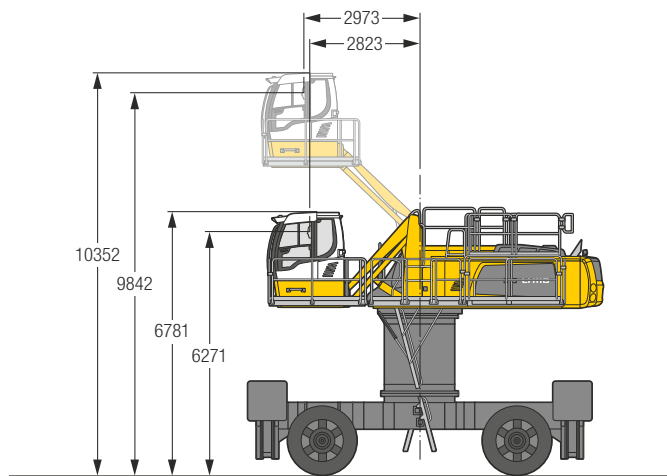

Increase type

LHC 360-50

The hydraulically adjustable cab allows the driver, that he can choose his field of view freely and at any time within the stroke.

Tyres 28.00-69

LH 110 C – Dimensions

Industry

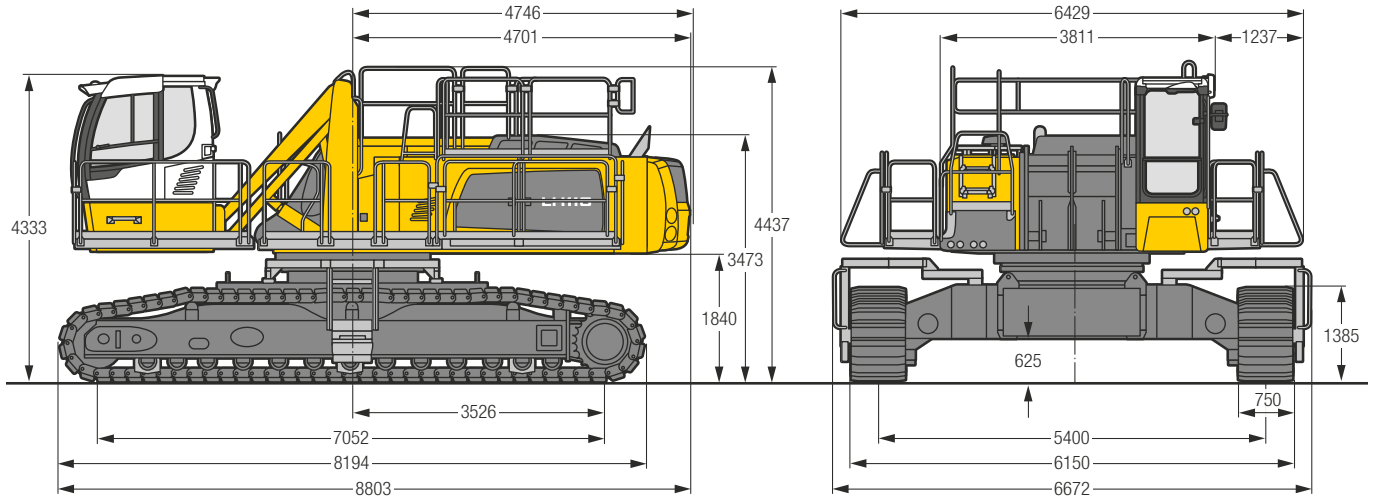

LH 110 C – Cab Elevation

Cab Elevation LHC (Hydraulic Elevation)

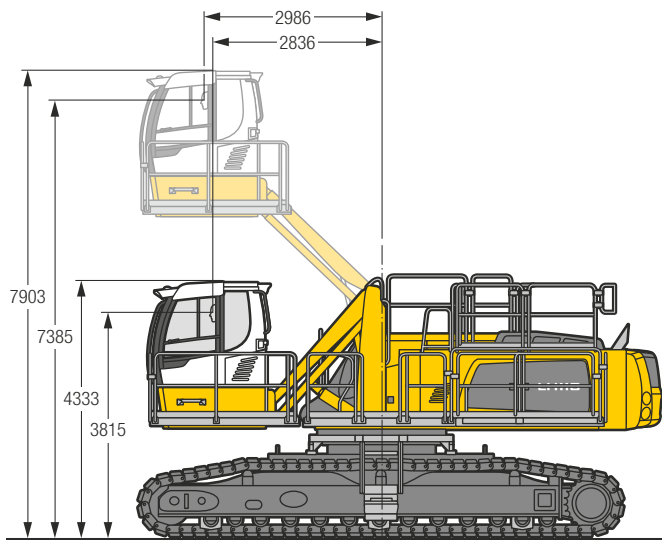

Increase type **LHC 360-50**
 The hydraulically adjustable cab allows the driver, that he can choose his field of view freely and at any time within the stroke.

LH 110 C HR – Dimensions

Industry

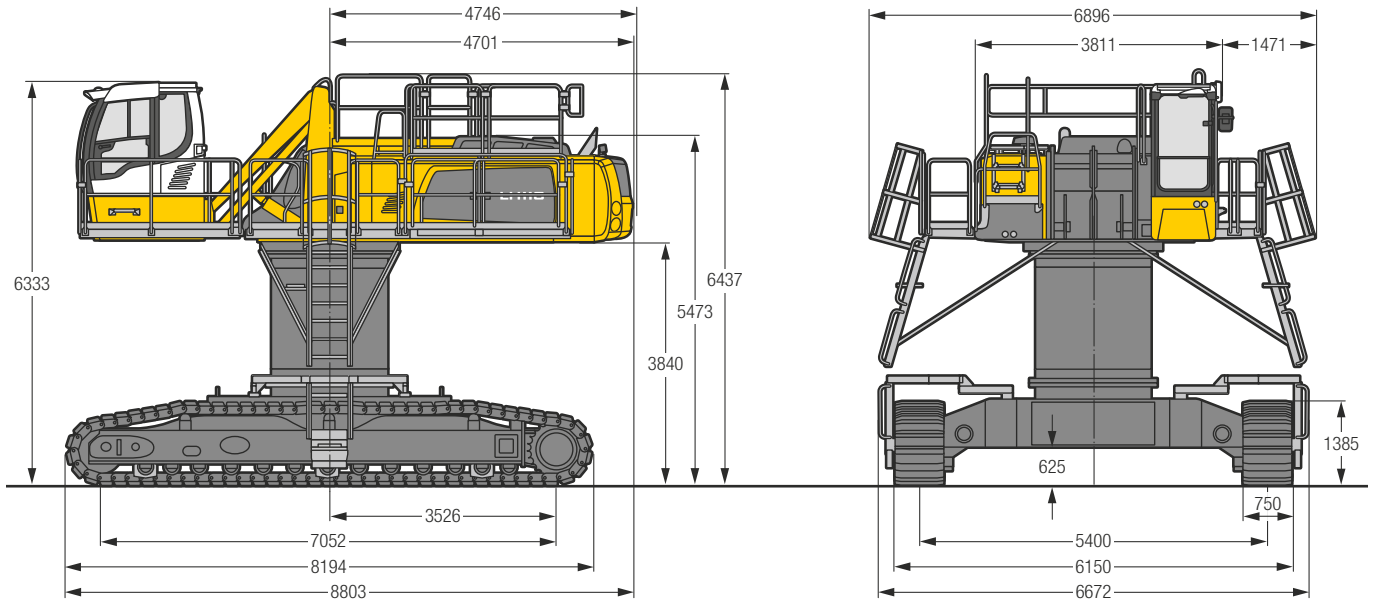

LH 110 C HR – Choice of Cab Elevation

Cab Elevation LHC (Hydraulic Elevation)

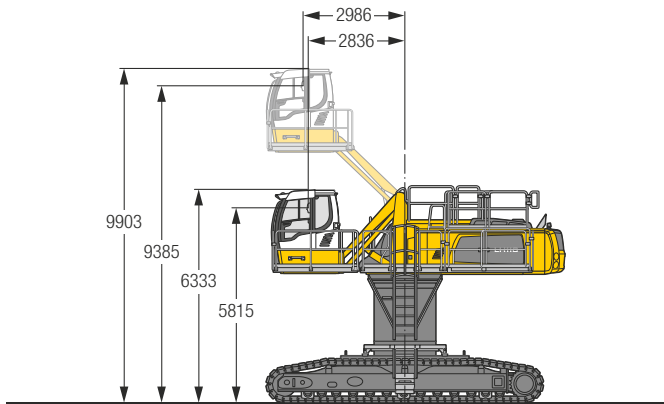

Increase type **LHC 360-50**
 The hydraulically adjustable cab allows the driver, that he can choose his field of view freely and at any time within the stroke.

Cab Elevation LHC-D (Hydraulic Elevation)

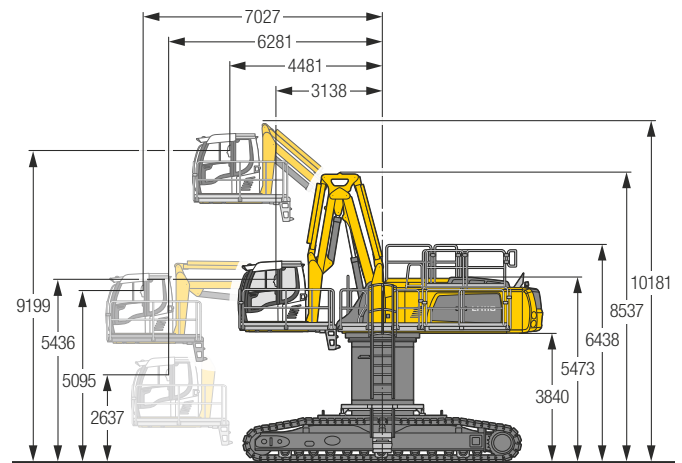

Increase type **LHC-D 730**
 The hydraulically adjustable cab allows the driver, that he can choose his field of view freely and at any time within the stroke.

LH 110 C Gantry – Dimensions

Industry

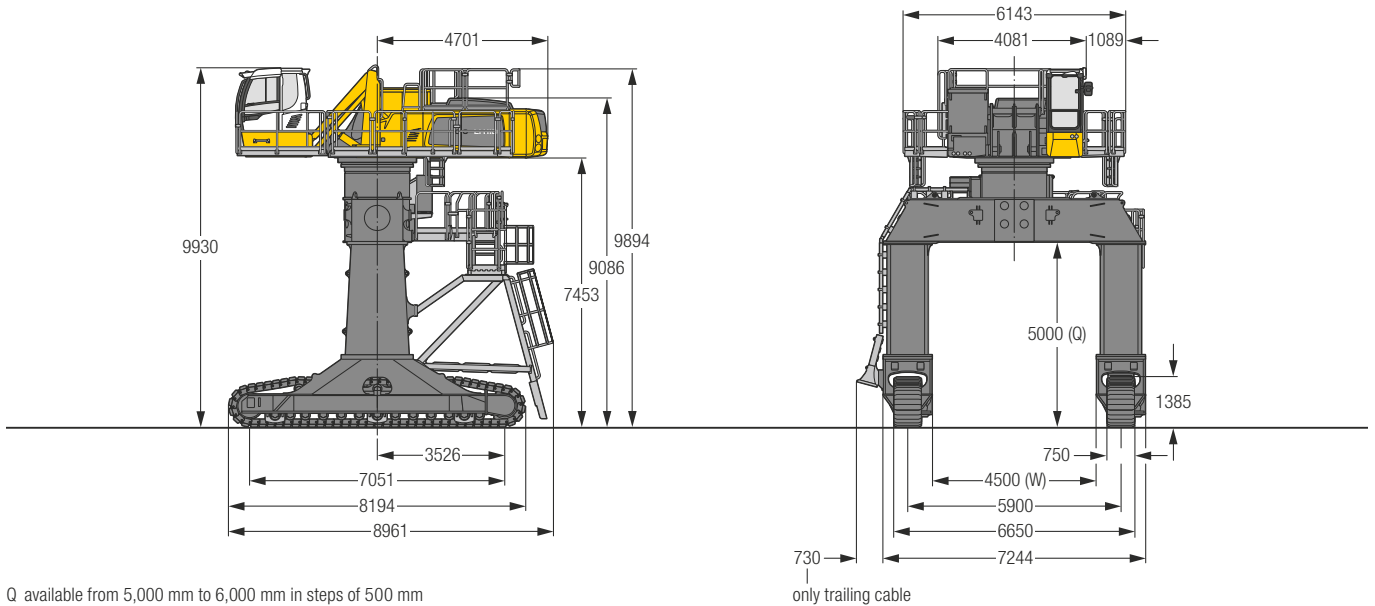

LH 110 C Gantry – Cab Elevation

Cab Elevation LHC (Hydraulic Elevation)

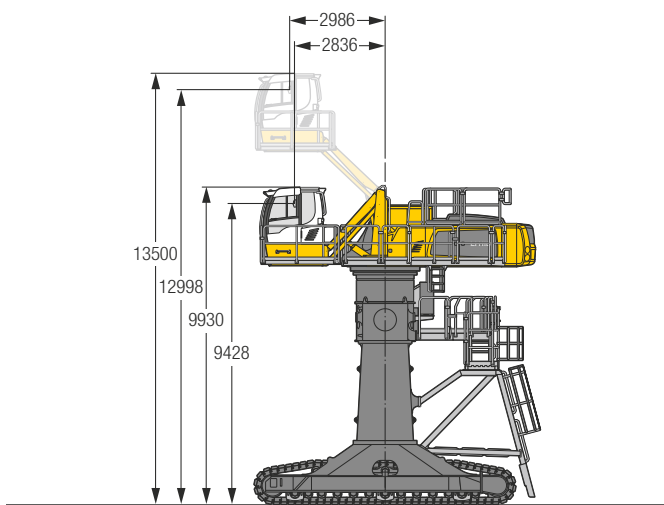

Increase type **LHC 360-50**
 The hydraulically adjustable cab allows the driver, that he can choose his field of view freely and at any time within the stroke.

Cab Elevation LHC-D (Hydraulic Elevation)

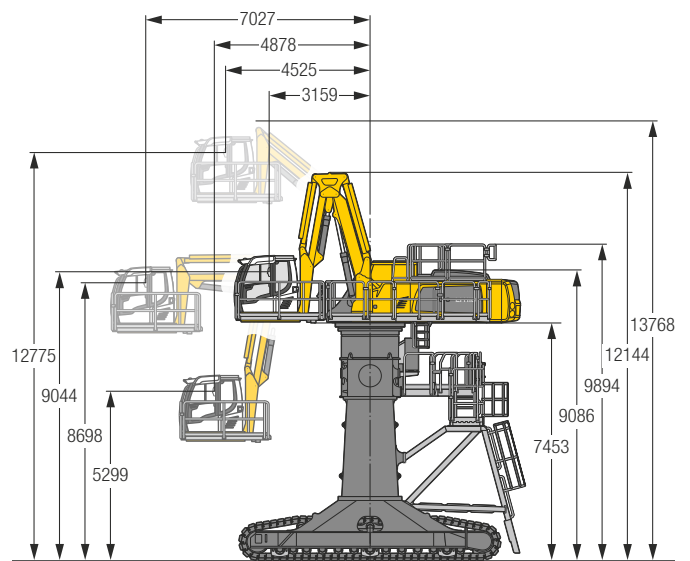

Increase type **LHC-D 730**
 The hydraulically adjustable cab allows the driver, that he can choose his field of view freely and at any time within the stroke.

Kinematic Variant 2A

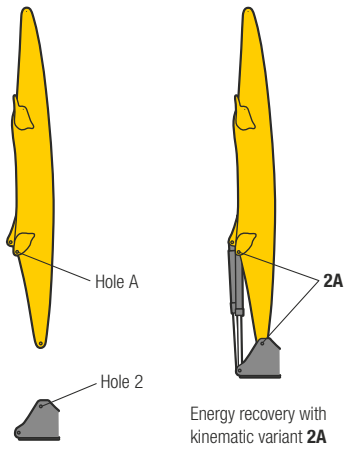

Kinematic Variant 2D/2C

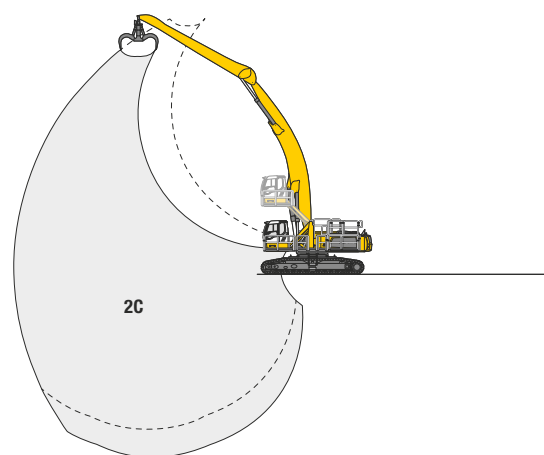
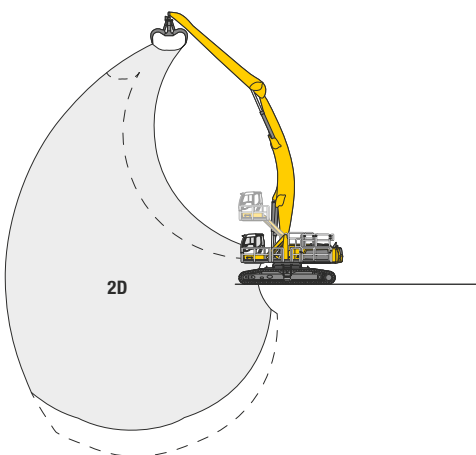
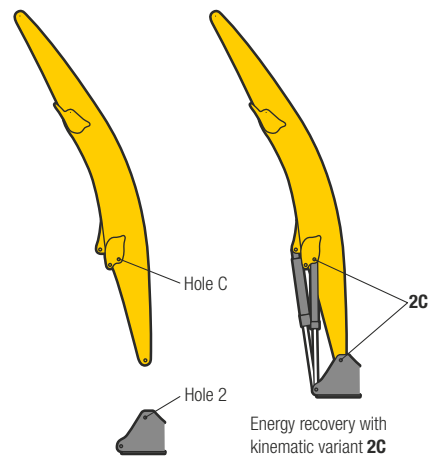
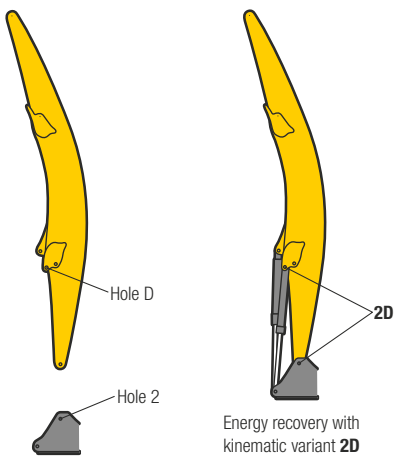

Altered range curve with additional reach depth, e.g. for unloading from ships

LH 110 M – Equipment GA22

Industry – Kinematic 2A

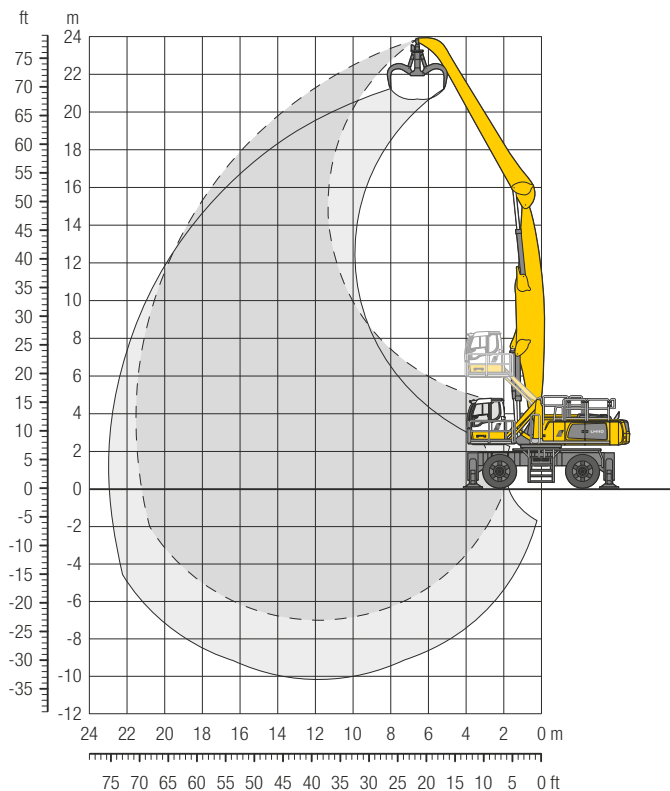









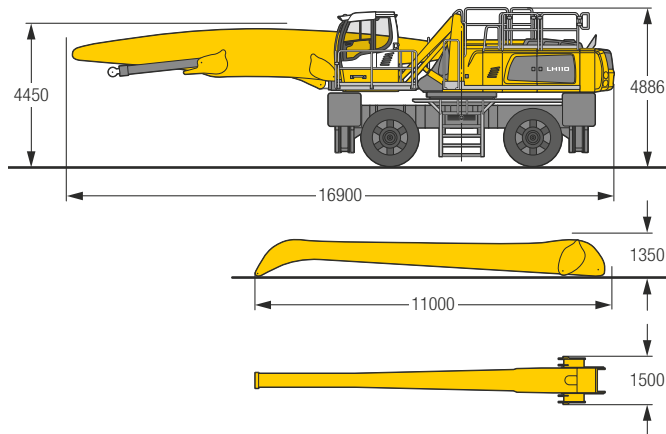







Operating Weight

The operating weight includes the basic machine with 4 point outriggers, hydr. cab elevation, 4 solid tyres, straight boom 11.50 m, angled stick 10.50 m and multi-tine grab GMM 120-5/ 2.00 m³ semi-closed tines.

Weight 98,500 kg

Dimensions



	6.0 m	7.5 m	9.0 m	10.5 m	12.0 m	13.5 m	15.0 m	16.5 m	18.0 m	19.5 m	21.0 m	22.5 m	24.0 m		
m														m	
Undercarriage															
28.5 4 pt. outriggers down															
27.0 4 pt. outriggers down															
25.5 4 pt. outriggers down															
24.0 4 pt. outriggers down															
22.5 4 pt. outriggers down			13.5*	13.5*										11.9* 11.9* 9.8	
21.0 4 pt. outriggers down				13.6*	13.6*	11.0*	11.0*							10.2* 10.2* 12.3	
19.5 4 pt. outriggers down				15.1*	15.1*	13.4*	13.4*	11.1*	11.1*					9.2* 9.2* 14.3	
18.0 4 pt. outriggers down						13.7*	13.7*	12.7*	12.7*	10.7*	10.7*			8.6* 8.6* 15.8	
16.5 4 pt. outriggers down						13.5*	13.5*	12.5*	12.5*	11.7*	11.7*	9.9*	9.9*	8.2* 8.2* 17.1	
15.0 4 pt. outriggers down						13.4*	13.4*	12.4*	12.4*	11.6*	11.6*	10.9*	10.9*	8.4* 8.4* 18.2	
13.5 4 pt. outriggers down						13.5*	13.5*	12.4*	12.4*	11.6*	11.6*	10.9*	10.9*	10.3* 10.3* 19.0	
12.0 4 pt. outriggers down						13.6*	13.6*	12.5*	12.5*	11.6*	11.6*	10.9*	10.9*	10.2* 10.2* 19.8	
10.5 4 pt. outriggers down				15.2*	15.2*	13.8*	13.8*	12.7*	12.7*	11.7*	11.7*	10.9*	10.9*	10.3* 10.3* 20.4	
9.0 4 pt. outriggers down				15.7*	15.7*	14.2*	14.2*	12.9*	12.9*	11.9*	11.9*	11.1*	11.1*	10.3* 10.3* 20.8	
7.5 4 pt. outriggers down			18.5*	18.5*	16.3*	16.3*	14.6*	14.6*	13.2*	12.1*	12.1*	11.2*	11.2*	10.4* 10.4* 21.2	
6.0 4 pt. outriggers down														9.7* 9.7* 21.4	
4.5 4 pt. outriggers down	30.6*	30.6*	22.9*	22.9*	19.5*	19.5*	17.0*	17.0*	15.1*	15.1*	13.6*	13.6*	12.4*	12.4*	11.4* 11.4* 21.5
3.0 4 pt. outriggers down	30.6*	30.6*	24.5*	24.5*	20.5*	20.5*	17.7*	17.7*	15.6*	15.6*	14.0*	14.0*	12.7*	12.7*	11.6* 11.6* 21.5
1.5 4 pt. outriggers down	33.3*	33.3*	26.1*	26.1*	21.6*	21.6*	18.4*	18.4*	16.1*	16.1*	14.3*	14.3*	12.9*	12.9*	11.7* 11.7* 21.5
0 4 pt. outriggers down	20.5*	20.5*	27.4*	27.4*	22.5*	22.5*	19.0*	19.0*	16.5*	16.5*	14.6*	14.6*	13.1*	13.1*	11.8* 11.8* 21.4
-1.5 4 pt. outriggers down	12.9*	12.9*	28.3*	28.3*	23.1*	23.1*	19.5*	19.5*	16.9*	16.9*	14.8*	14.8*	13.2*	13.2*	11.9* 11.9* 21.3
-3.0 4 pt. outriggers down	11.4*	11.4*	21.5*	21.5*	23.3*	23.3*	19.7*	19.7*	17.0*	17.0*	14.9*	14.9*	13.2*	13.2*	11.7* 11.7* 20.9
-4.5 4 pt. outriggers down	11.5*	11.5*	18.9*	18.9*	23.0*	23.0*	19.5*	19.5*	16.8*	16.8*	14.7*	14.7*	12.9*	12.9*	11.4* 11.4* 20.1
-6.0 4 pt. outriggers down	12.2*	12.2*	18.3*	18.3*	22.0*	22.0*	18.7*	18.7*	16.2*	16.2*	14.1*	14.1*	12.3*	12.3*	10.7* 10.7* 18.7
-6.0 4 pt. outriggers down			18.7*	18.7*	20.1*	20.1*	17.3*	17.3*	15.0*	15.0*	13.0*	13.0*	11.2*	11.2*	9.1* 9.1* 16.5

 **Height**  **Can be slewed through 360°**  **In longitudinal position of undercarriage**  **Max. reach** * Limited by hydr. capacity

The lift capacities on the stick end without attachment are stated in metric tons (t) and are valid on a firm, level supporting surface with blocked oscillating axle. These capacities can be slewed through 360° with the undercarriage in the transverse position. Capacities in the longitudinal position of the undercarriage (+/- 15°) are specified over the rigid axle with the stabilizers down. Indicated loads based on the ISO 10567 standard and do not exceed 75% of tipping or 87% of hydraulic capacity. The lift capacity values indicated are attained at the corresponding operating temperature. This operating temperature is ensured by continuous movement of the boom. Weights of fitted attachments (grabs, load hooks, etc.) and load accommodation attachment are to be deducted from the lift capacity values. The lift capacity of the unit is limited by its stability, the lifting capability of the hydraulic elements, or the maximum permissible lifting capacity of the load hook.

In accordance with the harmonised European Standard EN 474-5, hydraulic excavators used for lifting operations must be equipped with pipe fracture safety valves, an overload warning device, a load hook and a lift capacity chart.

LH 110 M HR – Equipment GA24

Industry – Kinematic 2A

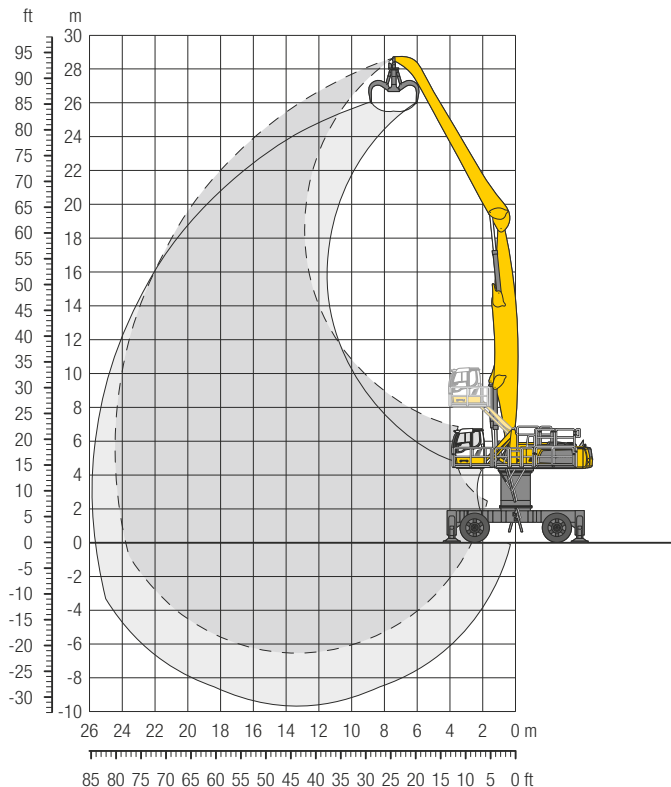

Operating Weight

The operating weight includes the basic machine with 4 point outriggers, turret 2,000 mm, hydr. cab elevation, 4 solid tyres, straight boom 13.00 m, angled stick 12.00 m and multi-tine grab GMM 120-5/1.70 m³ semi-closed tines.

Weight **107,500 kg**

Dimensions

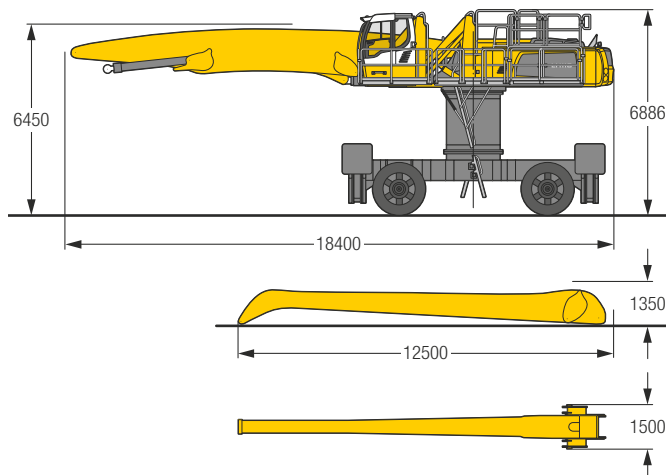

m	Undercarriage	Boom Length (m)												Outriggers		m														
		6.0	7.5	9.0	10.5	12.0	13.5	15.0	16.5	18.0	19.5	21.0	22.5	24.0	12.5		12.5													
28.5	4 pt. outriggers down																		12.5*	12.5*	7.8									
27.0	4 pt. outriggers down																		9.9*	9.9*	11.4									
25.5	4 pt. outriggers down					11.4*	11.4*												8.6*	8.6*	13.9									
24.0	4 pt. outriggers down							12.7*	12.7*	11.4*	11.4*	9.5*	9.5*						7.9*	7.9*	15.9									
22.5	4 pt. outriggers down									11.6*	11.6*	10.6*	10.6*	9.2*	9.2*				7.3*	7.3*	17.5									
21.0	4 pt. outriggers down									11.5*	11.5*	10.5*	10.5*	9.7*	9.7*	8.7*	8.7*		7.0*	7.0*	18.9									
19.5	4 pt. outriggers down									11.4*	11.4*	10.4*	10.4*	9.6*	9.6*	9.0*	9.0*	7.9*	7.9*		20.0									
18.0	4 pt. outriggers down									11.3*	11.3*	10.4*	10.4*	9.6*	9.6*	8.9*	8.9*	8.3*	8.3*	6.5*	6.5*	21.0								
16.5	4 pt. outriggers down									11.4*	11.4*	10.4*	10.4*	9.6*	9.6*	8.9*	8.9*	8.3*	8.3*	7.8*	7.8*	21.8								
15.0	4 pt. outriggers down									11.4*	11.4*	10.4*	10.4*	9.6*	9.6*	8.9*	8.9*	8.3*	8.3*	7.8*	7.8*	22.5								
13.5	4 pt. outriggers down							12.8*	12.8*	11.6*	11.6*	10.5*	10.5*	9.7*	9.7*	8.9*	8.9*	8.3*	8.3*	7.8*	7.8*	23.1								
12.0	4 pt. outriggers down							13.0*	13.0*	11.7*	11.7*	10.7*	10.7*	9.8*	9.8*	9.0*	9.0*	8.4*	8.4*	7.8*	7.8*	23.6								
10.5	4 pt. outriggers down									15.1*	15.1*	13.3*	13.3*	11.9*	11.9*	10.8*	10.8*	9.9*	9.9*	9.1*	9.1*	23.9								
9.0	4 pt. outriggers down																					24.2								
7.5	4 pt. outriggers down	18.0*	18.0*	21.8*	21.8*	18.7*	18.7*	16.0*	16.0*	14.0*	14.0*	12.4*	12.4*	11.2*	11.2*	10.1*	10.1*	9.3*	9.3*	8.5*	8.5*	7.9*	7.9*	7.3*	7.3*	6.6*	6.6*	6.3*	6.3*	24.4
6.0	4 pt. outriggers down	29.9*	29.9*	23.5*	23.5*	19.4*	19.4*	16.5*	16.5*	14.3*	14.3*	12.7*	12.7*	11.4*	11.4*	10.3*	10.3*	9.4*	9.4*	8.6*	8.6*	7.9*	7.9*	7.2*	7.2*	6.5*	6.5*	6.2*	6.2*	24.4
4.5	4 pt. outriggers down	26.7*	26.7*	24.5*	24.5*	20.0*	20.0*	16.9*	16.9*	14.7*	14.7*	12.9*	12.9*	11.5*	11.5*	10.4*	10.4*	9.4*	9.4*	8.6*	8.6*	7.9*	7.9*	7.2*	7.2*	6.4*	6.4*	6.1*	6.1*	24.4
3.0	4 pt. outriggers down	10.3*	10.3*	25.3*	25.3*	20.6*	20.6*	17.3*	17.3*	14.9*	14.9*	13.1*	13.1*	11.6*	11.6*	10.5*	10.5*	9.5*	9.5*	8.6*	8.6*	7.8*	7.8*	7.0*	7.0*	6.1*	6.1*	5.8*	5.8*	24.3
1.5	4 pt. outriggers down	8.0*	8.0*	16.2*	16.2*	20.9*	20.9*	17.5*	17.5*	15.1*	15.1*	13.2*	13.2*	11.7*	11.7*	10.5*	10.5*	9.4*	9.4*	8.5*	8.5*	7.7*	7.7*	6.8*	6.8*	5.7*	5.7*	5.6*	5.6*	24.1
0	4 pt. outriggers down	7.6*	7.6*	13.2*	13.2*	20.9*	20.9*	17.6*	17.6*	15.1*	15.1*	13.2*	13.2*	11.7*	11.7*	10.4*	10.4*	9.3*	9.3*	8.4*	8.4*	7.4*	7.4*	6.4*	6.4*	5.3*	5.3*	5.3*	5.3*	23.8
-1.5	4 pt. outriggers down	8.0*	8.0*	12.3*	12.3*	20.4*	20.4*	17.3*	17.3*	14.9*	14.9*	13.0*	13.0*	11.5*	11.5*	10.2*	10.2*	9.1*	9.1*	8.1*	8.1*	7.0*	7.0*	5.8*	5.8*	5.2*	5.2*	5.2*	5.2*	23.1
-3.0	4 pt. outriggers down	8.6*	8.6*	12.4*	12.4*	19.0*	19.0*	16.7*	16.7*	14.4*	14.4*	12.6*	12.6*	11.1*	11.1*	9.8*	9.8*	8.6*	8.6*	7.5*	7.5*	6.4*	6.4*	5.6*	5.6*	5.6*	5.6*	5.6*	5.6*	21.8
-4.5	4 pt. outriggers down			12.8*	12.8*	18.0*	18.0*	15.5*	15.5*	13.5*	13.5*	11.8*	11.8*	10.4*	10.4*	9.1*	9.1*	7.9*	7.9*	6.7*	6.7*	6.3*	6.3*	6.3*	6.3*	6.3*	6.3*	6.3*	6.3*	20.0
-6.0	4 pt. outriggers down					13.8*	13.8*	12.2*	12.2*	10.7*	10.7*	9.3*	9.3*	8.0*	8.0*															16.9

Height Can be slewed through 360° In longitudinal position of undercarriage Max. reach * Limited by hydr. capacity

The lift capacities on the stick end without attachment are stated in metric tons (t) and are valid on a firm, level supporting surface with blocked oscillating axle. These capacities can be slewed through 360° with the undercarriage in the transverse position. Capacities in the longitudinal position of the undercarriage (+/- 15°) are specified over the rigid axle with the stabilizers down. Indicated loads based on the ISO 10567 standard and do not exceed 75% of tipping or 87% of hydraulic capacity. The lift capacity values indicated are attained at the corresponding operating temperature. This operating temperature is ensured by continuous movement of the boom. Weights of fitted attachments (grabs, load hooks, etc.) and load accommodation attachment are to be deducted from the lift capacity values. The lift capacity of the unit is limited by its stability, the lifting capability of the hydraulic elements, or the maximum permissible lifting capacity of the load hook.

In accordance with the harmonised European Standard EN 474-5, hydraulic excavators used for lifting operations must be equipped with pipe fracture safety valves, an overload warning device, a load hook and a lift capacity chart.

LH 110 C – Equipment GA23

Industry – Kinematic 2A

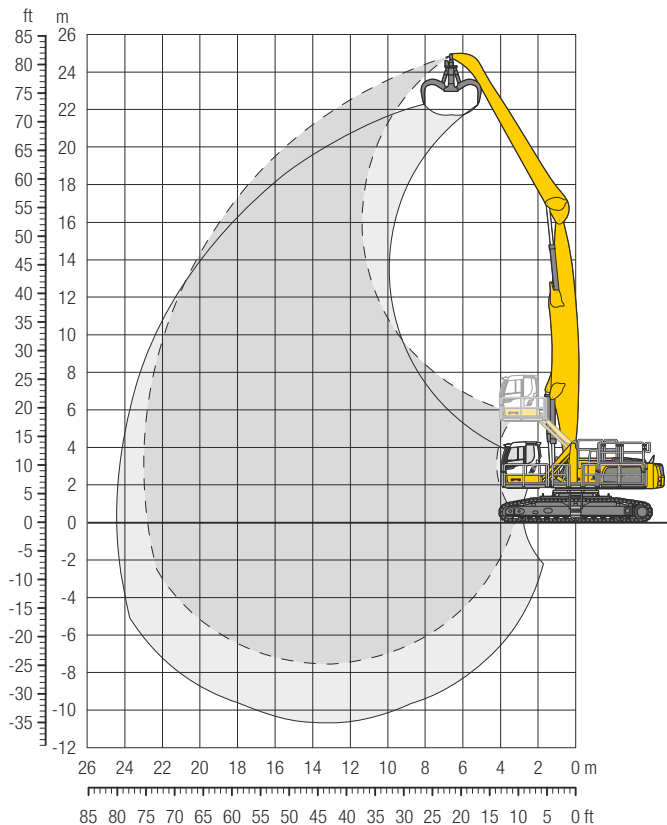

Operating Weight and Ground Pressure

The operating weight includes the basic machine with hydr. cab elevation, straight boom 13.00 m, angled stick 10.50 m and multi-tine grab GMM 120-5/2.00 m³ semi-closed tines.

Weight	104,500 kg
Pad width	750 mm
Ground pressure	on request

Dimensions

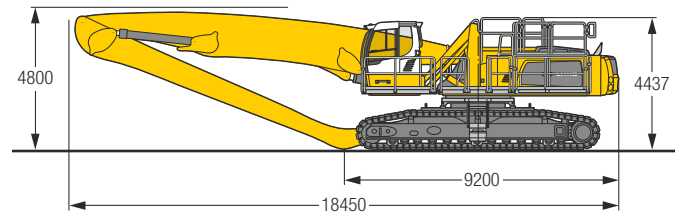

m	Undercarriage	Reach (m)												m												
		6.0 m	7.5 m	9.0 m	10.5 m	12.0 m	13.5 m	15.0 m	16.5 m	18.0 m	19.5 m	21.0 m	22.5 m		24.0 m											
24.0	SW			12.8*	12.8*													12.6*	12.6*	9.1						
22.5	SW				13.3*	13.3*	10.7*	10.7*											10.6*	10.6*	12.1					
21.0	SW				14.9*	14.9*	13.3*	13.3*	11.1*	11.1*									9.5*	9.5*	14.2					
19.5	SW						13.5*	13.5*	12.2*	12.2*	11.0*	11.0*							8.8*	8.8*	16.0					
18.0	SW						13.3*	13.3*	12.1*	12.1*	11.1*	11.1*	10.3*	10.3*					8.4*	8.4*	17.4					
16.5	SW						13.2*	13.2*	12.0*	12.0*	11.0*	11.0*	10.2*	10.2*	9.5*	9.5*			8.0*	8.0*	18.6					
15.0	SW						13.2*	13.2*	12.0*	12.0*	11.0*	11.0*	10.1*	10.1*	9.5*	9.5*	8.2*	8.2*			19.6					
13.5	SW						13.3*	13.3*	12.0*	12.0*	11.0*	11.0*	10.1*	10.1*	9.4*	9.4*	8.8*	8.8*			20.5					
12.0	SW						13.4*	13.4*	12.1*	12.1*	11.1*	11.1*	10.2*	10.2*	9.4*	9.4*	8.8*	8.8*	8.1*	8.1*	21.2					
10.5	SW				15.3*	15.3*	13.6*	13.6*	12.3*	12.3*	11.2*	11.2*	10.3*	10.3*	9.5*	9.5*	8.8*	8.8*	8.2*	8.2*	21.8					
9.0	SW			18.0*	18.0*	15.7*	15.7*	13.9*	13.9*	12.4*	12.4*	11.3*	11.3*	10.3*	10.3*	9.5*	9.5*	8.9*	8.9*	8.2*	8.2*	22.2				
7.5	SW		21.1*	21.1*	18.6*	18.6*	16.1*	16.1*	14.2*	14.2*	12.7*	12.7*	11.5*	11.5*	10.5*	10.5*	9.6*	9.6*	8.9*	8.9*	8.2*	8.2*	7.6*	7.6*	22.6	
6.0	SW	27.2*	27.2*	23.2*	23.2*	19.3*	19.3*	16.6*	16.6*	14.5*	14.5*	12.9*	12.9*	11.6*	11.6*	10.6*	10.6*	9.7*	9.7*	8.9*	8.9*	8.2*	8.2*	7.5*	7.5*	22.8
4.5	SW	31.0*	31.0*	24.3*	24.3*	20.0*	20.0*	17.1*	17.1*	14.9*	14.9*	13.2*	13.2*	11.8*	11.8*	10.7*	10.7*	9.8*	9.8*	9.0*	9.0*	8.2*	8.2*	7.5*	7.5*	23.0
3.0	SW	14.9*	14.9*	25.3*	25.3*	20.7*	20.7*	17.5*	17.5*	15.2*	15.2*	13.4*	13.4*	12.0*	12.0*	10.8*	10.8*	9.8*	9.8*	9.0*	9.0*	8.2*	8.2*	7.3*	7.3*	23.0
1.5	SW	7.7*	7.7*	20.5*	20.5*	21.2*	21.2*	17.9*	17.9*	15.4*	15.4*	13.6*	13.6*	12.1*	12.1*	10.9*	10.9*	9.8*	9.8*	8.9*	8.9*	8.1*	8.1*	7.1*	7.1*	22.9
0	SW	6.5*	6.5*	13.6*	13.6*	21.5*	21.5*	18.1*	18.1*	15.6*	15.6*	13.7*	13.7*	12.1*	12.1*	10.9*	10.9*	9.8*	9.8*	8.8*	8.8*	7.9*	7.9*	6.7*	6.7*	22.8
-1.5	SW	6.7*	6.7*	11.9*	11.9*	21.4*	21.4*	18.1*	18.1*	15.6*	15.6*	13.6*	13.6*	12.1*	12.1*	10.8*	10.8*	9.6*	9.6*	8.6*	8.6*	7.5*	7.5*	6.1*	6.1*	22.5
-3.0	SW	7.4*	7.4*	11.6*	11.6*	19.3*	19.3*	17.7*	17.7*	15.3*	15.3*	13.4*	13.4*	11.8*	11.8*	10.5*	10.5*	9.3*	9.3*	8.2*	8.2*	7.0*	7.0*			22.0
-4.5	SW	8.4*	8.4*	12.0*	12.0*	18.4*	18.4*	16.9*	16.9*	14.7*	14.7*	12.9*	12.9*	11.3*	11.3*	10.0*	10.0*	8.8*	8.8*	7.5*	7.5*					20.7
-6.0	SW			17.8*	17.8*	15.6*	15.6*	13.6*	13.6*	12.0*	12.0*	10.5*	10.5*	9.2*	9.2*	7.9*	7.9*									18.8
-7.5	SW							10.6*	10.6*																	14.0

Height
Can be slewed through 360°
In longitudinal position of undercarriage
Max. reach
 * Limited by hydr. capacity

The lift capacities on the stick end without attachment are stated in metric tons (t) and can be slewed through 360° on a firm, level supporting surface. Capacities are valid for 750 mm wide flat pads. Indicated loads based on the ISO 10567 standard and do not exceed 75% of tipping or 87% of hydraulic capacity. The lift capacity values indicated are attained at the corresponding operating temperature. This operating temperature is ensured by continuous movement of the boom. Weights of fitted attachments (grabs, load hooks, etc.) and load accommodation attachment are to be deducted from the lift capacity values. The lift capacity of the unit is limited by its stability, the lifting capability of the hydraulic elements, or the maximum permissible lifting capacity of the load hook.

In accordance with the harmonised European Standard EN 474-5, hydraulic excavators used for lifting operations must be equipped with pipe fracture safety valves, an overload warning device, a load hook and a lift capacity chart.

LH 110 C HR – Equipment AG24

Industry – Kinematic 2D

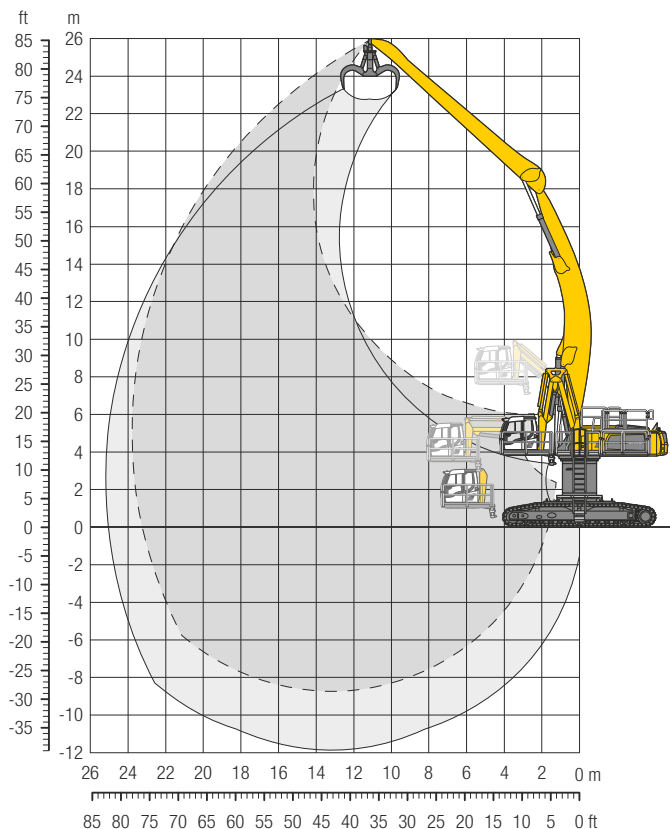

Operating Weight and Ground Pressure

The operating weight includes the basic machine with turret 2,000 mm, hydr. cab elevation, angled boom 13.00 m, straight stick 12.00 m and multi-tine grab GMM 120-5/1.70 m³ semi-closed tines.

Weight	112,000 kg
Pad width	750 mm
Ground pressure	on request

Dimensions

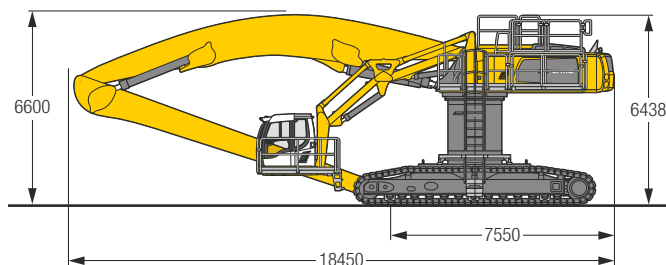

m	Undercarriage	6.0 m	7.5 m	9.0 m	10.5 m	12.0 m	13.5 m	15.0 m	16.5 m	18.0 m	19.5 m	21.0 m	22.5 m	24.0 m	m			
		8.6"	8.6"	11.9	8.8"	8.8"	8.8"	8.8"	8.3"	8.3"	7.7"	7.7"	7.2"	7.2"		7.2"	7.2"	14.2
25.5	SW						8.8"	8.8"							7.7"	7.7"	14.2	
24.0	SW						9.7"	9.7"	8.8"	8.8"					7.2"	7.2"	16.1	
22.5	SW								8.8"	8.8"	8.3"	8.3"			6.8"	6.8"	17.6	
21.0	SW								8.7"	8.7"	8.2"	8.2"	7.7"	7.7"	6.6"	6.6"	18.8	
19.5	SW								8.7"	8.7"	8.1"	8.1"	7.6"	7.6"	6.4"	6.4"	19.9	
18.0	SW								8.7"	8.7"	8.1"	8.1"	7.6"	7.6"	6.3"	6.3"	20.8	
16.5	SW								8.7"	8.7"	8.1"	8.1"	7.6"	7.6"	6.2"	6.2"	21.6	
15.0	SW						9.6"	9.6"	8.8"	8.8"	8.2"	8.2"	7.7"	7.7"	6.2"	6.2"	22.2	
13.5	SW						9.8"	9.8"	9.0"	9.0"	8.3"	8.3"	7.8"	7.8"	6.2"	6.2"	22.7	
12.0	SW						11.1"	11.1"	10.0"	10.0"	9.2"	9.2"	8.5"	8.5"	6.3"	6.3"	23.2	
10.5	SW								11.1"	11.1"	10.0"	10.0"	9.2"	9.2"	6.4"	6.4"	23.5	
9.0	SW				12.9"	12.9"	11.4"	11.4"	10.3"	10.3"	9.4"	9.4"	8.7"	8.7"	6.5"	6.5"	23.7	
7.5	SW			15.5"	15.5"	13.5"	13.5"	11.9"	11.9"	10.6"	10.6"	9.7"	9.7"	8.9"	8.9"	6.5"	6.5"	23.8
6.0	SW	24.9"	24.9"	19.8"	19.8"	16.4"	16.4"	14.1"	14.1"	12.3"	12.3"	11.0"	11.0"	9.9"	9.9"	6.5"	6.5"	23.8
4.5	SW	27.1"	27.1"	21.2"	21.2"	17.4"	17.4"	14.8"	14.8"	12.8"	12.8"	11.4"	11.4"	10.2"	10.2"	6.6"	6.6"	23.8
3.0	SW	17.2"	17.2"	22.4"	22.4"	18.3"	18.3"	15.4"	15.4"	13.3"	13.3"	11.8"	11.8"	10.5"	10.5"	6.6"	6.6"	23.7
1.5	SW	11.2"	11.2"	22.2"	22.2"	19.1"	19.1"	16.0"	16.0"	13.8"	13.8"	12.1"	12.1"	10.8"	10.8"	6.6"	6.6"	23.5
0	SW	9.7"	9.7"	16.3"	16.3"	19.7"	19.7"	16.5"	16.5"	14.2"	14.2"	12.4"	12.4"	11.1"	11.1"	6.7"	6.7"	23.2
-1.5	SW	9.5"	9.5"	14.3"	14.3"	20.1"	20.1"	16.9"	16.9"	14.5"	14.5"	12.7"	12.7"	11.3"	11.3"	6.7"	6.7"	22.8
-3.0	SW	9.7"	9.7"	13.6"	13.6"	20.3"	20.3"	17.1"	17.1"	14.7"	14.7"	12.8"	12.8"	11.4"	11.4"	6.7"	6.7"	22.3
-4.5	SW	10.1"	10.1"	13.5"	13.5"	19.4"	19.4"	17.0"	17.0"	14.6"	14.6"	12.8"	12.8"	11.3"	11.3"	6.6"	6.6"	21.7
-6.0	SW	10.6"	10.6"	13.7"	13.7"	19.1"	19.1"	16.6"	16.6"	14.3"	14.3"	12.5"	12.5"	11.1"	11.1"	6.7"	6.7"	20.8
-7.5	SW			18.3"	18.3"	15.7"	15.7"	13.6"	13.6"	12.0"	12.0"	10.5"	10.5"	9.3"	9.3"	7.7"	7.7"	18.5

Height
 Can be slewed through 360°
 In longitudinal position of undercarriage
 Max. reach
 * Limited by hydr. capacity

The lift capacities on the stick end without attachment are stated in metric tons (t) and can be slewed through 360° on a firm, level supporting surface. Capacities are valid for 750 mm wide flat pads. Indicated loads based on the ISO 10567 standard and do not exceed 75% of tipping or 87% of hydraulic capacity. The lift capacity values indicated are attained at the corresponding operating temperature. This operating temperature is ensured by continuous movement of the boom. Weights of fitted attachments (grabs, load hooks, etc.) and load accommodation attachment are to be deducted from the lift capacity values. The lift capacity of the unit is limited by its stability, the lifting capability of the hydraulic elements, or the maximum permissible lifting capacity of the load hook.

In accordance with the harmonised European Standard EN 474-5, hydraulic excavators used for lifting operations must be equipped with pipe fracture safety valves, an overload warning device, a load hook and a lift capacity chart.

LH 110 C Gantry – Equipment AG24

Industry – Kinematic 2D

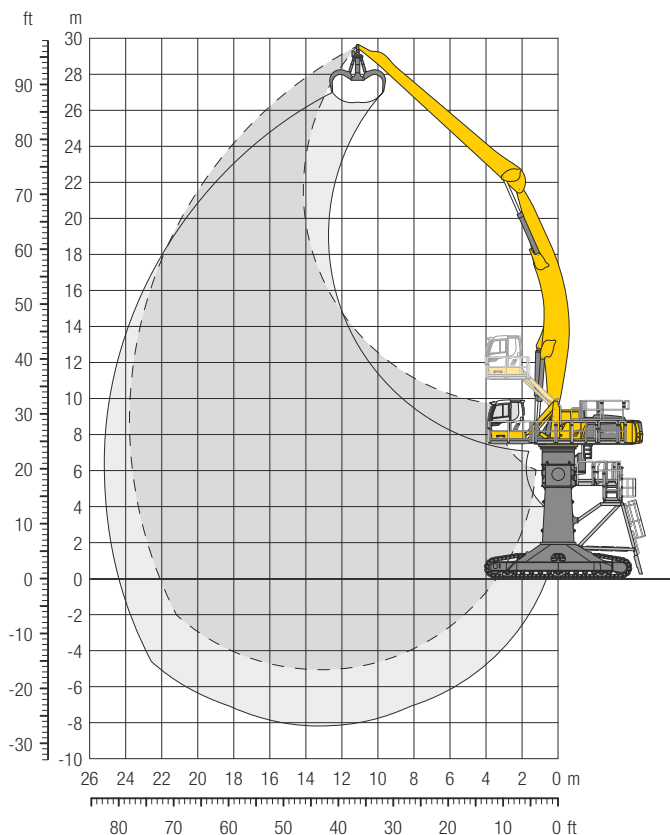

Operating Weight and Ground Pressure

The operating weight includes the basic machine with hydr. cab elevation, angled boom 13.00 m, straight stick 12.00 m and multi-tine grab GMM 120-5/1.70 m³ semi-closed tines.

Weight	123,600 kg
Pad width	750 mm
Ground pressure	on request

Dimensions

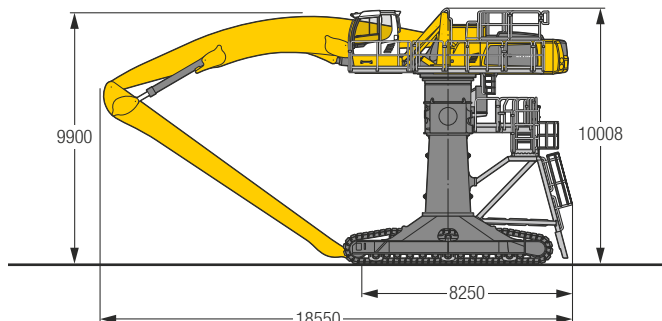

m	Undercarriage	Boom Length (m)												m								
		6.0 m	7.5 m	9.0 m	10.5 m	12.0 m	13.5 m	15.0 m	16.5 m	18.0 m	19.5 m	21.0 m	22.5 m	24.0 m	8.2*	8.2*	m					
28.5	Gantry					9.5*	9.5*												8.2*	8.2*	13.0	
27.0	Gantry							9.6*	9.6*	7.6*	7.6*									7.5*	7.5*	15.1
25.5	Gantry							9.6*	9.6*	8.9*	8.9*	7.4*	7.4*							7.0*	7.0*	16.7
24.0	Gantry									8.8*	8.8*	8.2*	8.2*	7.0*	7.0*					6.7*	6.7*	18.1
22.5	Gantry									8.7*	8.7*	8.1*	8.1*	7.7*	7.7*					6.5*	6.5*	19.3
21.0	Gantry									8.7*	8.7*	8.1*	8.1*	7.6*	7.6*	7.2*	7.2*			6.4*	6.4*	20.3
19.5	Gantry									8.7*	8.7*	8.1*	8.1*	7.6*	7.6*	7.2*	7.2*	6.7*	6.7*	6.3*	6.3*	21.2
18.0	Gantry									8.8*	8.8*	8.2*	8.2*	7.7*	7.7*	7.2*	7.2*	6.9*	6.9*	6.2*	6.2*	21.9
16.5	Gantry							9.7*	9.7*	8.9*	8.9*	8.3*	8.3*	7.7*	7.7*	7.3*	7.3*	6.9*	6.9*	6.2*	6.2*	22.5
15.0	Gantry							9.9*	9.9*	9.1*	9.1*	8.4*	8.4*	7.8*	7.8*	7.4*	7.4*	7.0*	7.0*	6.6*	6.6*	22.9
13.5	Gantry							11.2*	11.2*	10.1*	10.1*	9.3*	9.3*	8.6*	8.6*	8.0*	8.0*	7.5*	7.5*	7.0*	7.0*	23.3
12.0	Gantry									10.5*	10.5*	9.5*	9.5*	8.7*	8.7*	8.1*	8.1*	7.6*	7.6*	7.1*	7.1*	23.6
10.5	Gantry									11.6*	11.6*	10.8*	10.8*	9.8*	9.8*	9.0*	9.0*	8.3*	8.3*	7.7*	7.7*	23.7
9.0	Gantry	25.9*	25.9*	20.4*	20.4*	16.8*	16.8*	14.4*	14.4*	12.6*	12.6*	11.2*	11.2*	10.1*	10.1*	9.2*	9.2*	8.5*	8.5*	7.8*	7.8*	23.8
7.5	Gantry	28.0*	28.0*	21.7*	21.7*	17.8*	17.8*	15.0*	15.0*	13.0*	13.0*	11.5*	11.5*	10.4*	10.4*	9.4*	9.4*	8.6*	8.6*	8.0*	8.0*	23.8
6.0	Gantry	13.6*	13.6*	22.9*	22.9*	18.6*	18.6*	15.7*	15.7*	13.5*	13.5*	11.9*	11.9*	10.7*	10.7*	9.6*	9.6*	8.8*	8.8*	8.1*	8.1*	23.6
4.5	Gantry	10.3*	10.3*	18.8*	18.8*	19.4*	19.4*	16.2*	16.2*	14.0*	14.0*	12.3*	12.3*	10.9*	10.9*	9.9*	9.9*	9.0*	9.0*	8.3*	8.3*	23.4
3.0	Gantry	9.5*	9.5*	15.2*	15.2*	19.9*	19.9*	16.7*	16.7*	14.3*	14.3*	12.6*	12.6*	11.2*	11.2*	10.0*	10.0*	9.1*	9.1*	8.3*	8.3*	23.1
1.5	Gantry	9.5*	9.5*	13.9*	13.9*	20.2*	20.2*	17.0*	17.0*	14.6*	14.6*	12.8*	12.8*	11.3*	11.3*	10.1*	10.1*	9.2*	9.2*	8.3*	8.3*	22.6
0	Gantry	9.8*	9.8*	13.5*	13.5*	20.0*	20.0*	17.1*	17.1*	14.7*	14.7*	12.8*	12.8*	11.4*	11.4*	10.2*	10.2*	9.1*	9.1*	8.2*	8.2*	22.1
-1.5	Gantry	10.3*	10.3*	13.6*	13.6*	19.2*	19.2*	16.8*	16.8*	14.5*	14.5*	12.7*	12.7*	11.2*	11.2*	10.0*	10.0*	8.9*	8.9*	8.0*	8.0*	21.4
-3.0	Gantry			13.9*	13.9*	19.0*	19.0*	16.2*	16.2*	14.1*	14.1*	12.3*	12.3*	10.9*	10.9*	9.6*	9.6*	8.5*	8.5*	7.4*	7.4*	19.9
-4.5	Gantry					15.2*	15.2*	13.2*	13.2*	11.6*	11.6*	10.2*	10.2*	8.9*	8.9*					8.6*	8.6*	16.9

 **Height**
 **Can be slewed through 360°**
 **In longitudinal position of undercarriage**
 **Max. reach**
 * Limited by hydr. capacity

The lift capacities on the stick end without attachment are stated in metric tons (t) and can be slewed through 360° on a firm, level supporting surface. Capacities are valid for 750 mm wide flat pads. Indicated loads based on the ISO 10567 standard and do not exceed 75% of tipping or 87% of hydraulic capacity. The lift capacity values indicated are attained at the corresponding operating temperature. This operating temperature is ensured by continuous movement of the boom. Weights of fitted attachments (grabs, load hooks, etc.) and load accommodation attachment are to be deducted from the lift capacity values. The lift capacity of the unit is limited by its stability, the lifting capability of the hydraulic elements, or the maximum permissible lifting capacity of the load hook.

In accordance with the harmonised European Standard EN 474-5, hydraulic excavators used for lifting operations must be equipped with pipe fracture safety valves, an overload warning device, a load hook and a lift capacity chart.



Liebherr ERC-System

ERC System – More Performance, Less Consumption

Lowering the equipment stores energy in the ERC system. This stored energy is then made available to the machine to provide additional engine power. When the equipment is raised the stored energy is released and is reflected in

powerful, homogeneous operating cycles. The result is a clear saving on fuel – and, at the same time, even greater performance.

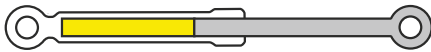

B 1. Equipment fitting raised/
Energy released



2. Lower equipment fitting/Store energy
4. Raise equipment fitting/Release energy



A 3. Equipment fitting lowered/
Energy stored

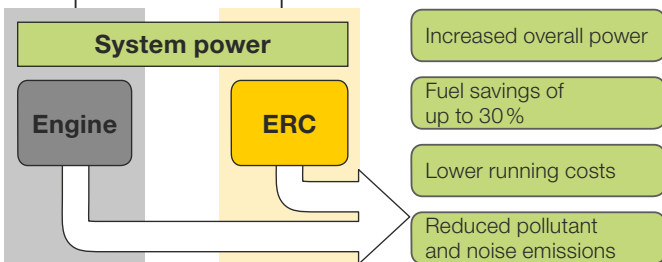
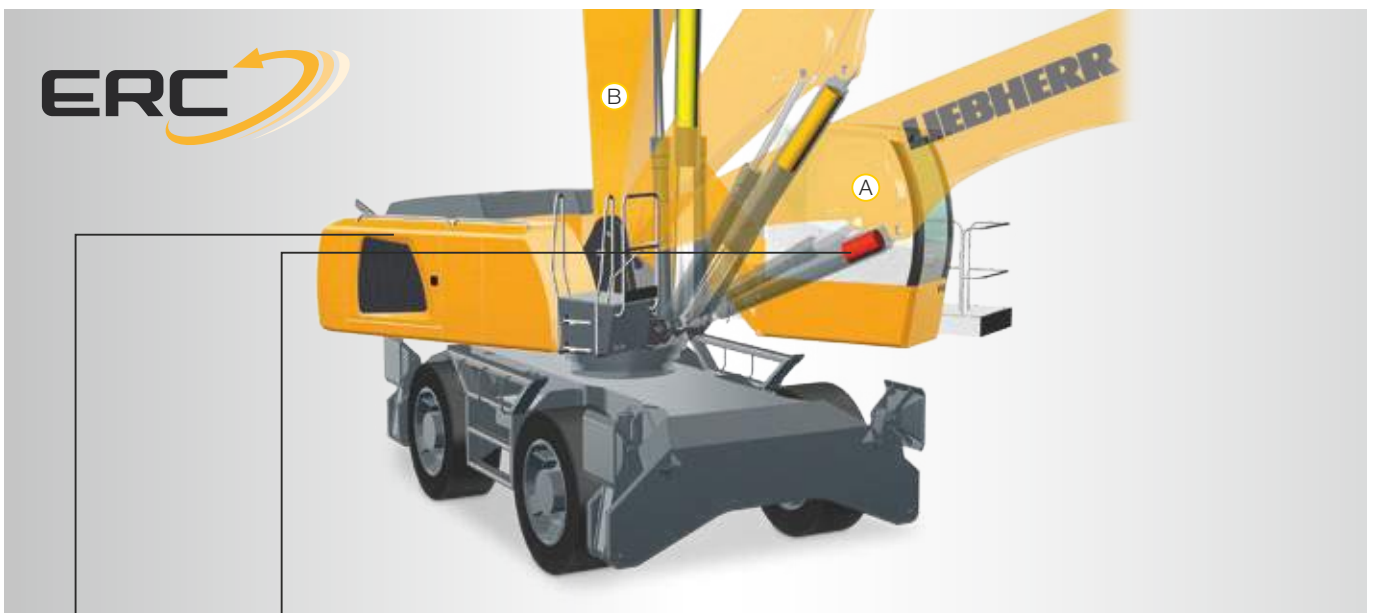

System Power

The energy recovery cylinder is a storage system which is independent of the diesel engine. The system performance of material handling machines fitted with the ERC system is composed of the installed engine power and the energy recovery cylinder. When the equipment is raised, energy from the ERC system is supplied in addition to the power from the diesel engine.

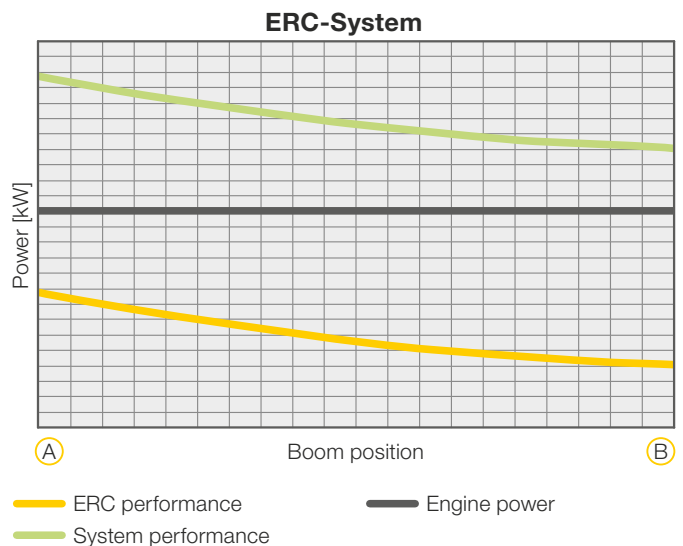

Attachments



Multi-Tine Grab

		open			semi-closed			closed					
Grab model GMM 80-4 (4 tines)													
Capacity	m ³	1.10	1.40	1.70	1.10	1.40	1.70		1.40*				
Weight	kg	1,895	1,935	1,995	2,090	2,150	2,210		2,430				
Grab model GMM 80-5 (5 tines)													
Capacity	m ³	1.10	1.40	1.70	1.10	1.40	1.70		1.10*	1.40*	1.70*		
Weight	kg	2,170	2,220	2,290	2,390	2,465	2,540		2,440	2,580	2,740		
Grab model GMM 120-4 (4 tines)													
Capacity	m ³	1.70	2.00	2.50	3.00	1.70	2.00	2.50	3.00				
Weight	kg	2,155	2,200	2,255	2,305	2,415	2,470	2,560	2,655				
Grab model GMM 120-5 (5 tines)													
Capacity	m ³	1.70	2.00	2.50	3.00	1.70	2.00	2.50	3.00	1.70	2.00	2.50	3.00
Weight	kg	2,485	2,540	2,610	2,675	2,785	2,850	2,965	3,085				

* heart-shaped

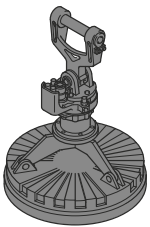

Magnet Devices / Lifting Magnets

Generator	kW	30		30
Electromagnet with suspension				
Power	kW	17.8		22
Diameter of magnet	mm	1,700		1,900
Weight	kg	3,280*		5,090*

* only magnet plate

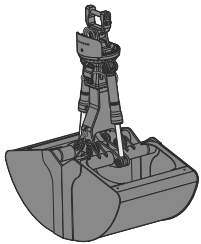

Grab for Loose Material

Shells for loose material with cutting edge (without teeth)

Grab model GMZ 80							
Width of shells	mm	1,300	1,500	1,750	2,000	2,200	2,600
Capacity	m ³	3.00	3.50	4.00	4.50	5.00	6.00
Weight	kg	2,510	2,625	2,770	2,940	3,035	3,265
Grab model GMZ 120							
Width of shells	mm	1,800	2,000	2,200	2,400	2,800	3,200
Capacity	m ³	4.50	5.00	5.50	6.00	7.00	8.00
Weight	kg	3,200	3,335	3,425	3,610	3,825	4,160

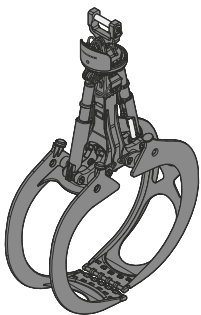

Wood Grab

Grab model GMH 80 Rundform (complete overlapping, vertical cylinders)							
Size	m ²	1.60		1.90		2.20	2.50
Cutting width	mm	870		870		870	870
Height of grab, closed	mm	2,908		2,984		3,062	3,140
Weight	kg	2,260		2,305		2,340	2,380
Grab model GMH 120 Rundform (complete overlapping, vertical cylinders)							
Size	m ²	2.80		3.20			
Cutting width	mm	870		870			
Height of grab, closed	mm	3,574		3,673			
Weight	kg	2,770		2,800			

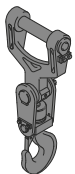



Load Hook

Max. load	t	25
Weight	kg	255

Equipment

	110 M	110 C	110 M HR	110 C HR	110 C Gantry
 Undercarriage					
Track pads, variants		+		+	+
Individual control outriggers	+		•		
Three-piece chain guide		•		•	•
Shuttle axle lock, automatic	•		•		
Outrigger monitoring system	+		+		
Tyres, variants	+		+		
Trailing cable ²⁾		•		•	•
Protection for piston rods, outriggers	+		+		
Two lockable storage compartments	•				
Cable reel system ²⁾		+		+	+

	110 M	110 C	110 M HR	110 C HR	110 C Gantry
 Uppercarriage					
Uppercarriage right side light, 1 piece, LED	•	•	•	•	•
Uppercarriage rear light, 2 pieces, LED	+	+			
Uppercarriage underneath rear light, 1 piece, LED			+	+	+
Refuelling system with filling pump ¹⁾	+	+	+	+	+
Railing on uppercarriage	•	•	•	•	•
Generator	+	+	+	+	+
Main battery switch for electrical system	•	•	•	•	•
Amber beacon, at uppercarriage, LED double flash	+	+	+	+	+
Protection for headlights	+	+			
Tool equipment, extended	•	•	•	•	•

	110 M	110 C	110 M HR	110 C HR	110 C Gantry
 Hydraulic System					
Electronic pump regulation	•	•	•	•	•
Liebherr hydraulic oil from -20 °C to +40 °C	•	•	•	•	•
Liebherr hydraulic oil, biologically degradable	+	+	+	+	+
Liebherr hydraulic oil, specially for warm or cold regions	+	+	+	+	+
Magnetic rod in hydraulic tank	•	•	•	•	•
Bypass filter	+	+	+	+	+
Preheating hydraulic oil	+	+	+	+	+

	110 M	110 C	110 M HR	110 C HR	110 C Gantry
 Engine					
Fuel anti-theft device ¹⁾	+	+	+	+	+
Air pre-filter with dust discharge	+	+	+	+	+
Automatic engine shut-down (time adjustable)	+	+	+	+	+
Preheating fuel ¹⁾	+	+	+	+	+
Preheating coolant*	+	+	+	+	+
Preheating engine oil* ¹⁾	+	+	+	+	+

	110 M	110 C	110 M HR	110 C HR	110 C Gantry
 Cooling System					
Reversible fan drive, fully automatic	+	+	+	+	+
Protective grid in front of cooler intake	•	•	•	•	•



Operator's Cab

	110 M	110 C	110 M HR	110 C HR	110 C Gantry
Stabilizer, control lever, left console	+		+		
Stabilizer, proportional control on left joystick	•		•		
Cab lights rear, LED	+	+	+	+	+
Cab lights front, LED	+	+	+	+	+
Cab lights front, LED (under rain cover)	•	•	•	•	•
Armrest adjustable	•	•	•	•	•
Circular bubble level	•	•	•	•	•
Slewing gear brake Comfort, button on the left or right joystick	+	+	+	+	+
Driver profile, personalised (max. 5 drivers)	+	+	+	+	+
Operator's seat Comfort	•	•	•	•	•
Operator's seat Premium	+	+	+	+	+
Driving alarm (acoustic signal is emitted during travel, can be switched ON / OFF)	+	+	+	+	+
Fire extinguisher	+	+	+	+	+
Footrest	+	+	+	+	+
Horn, button on left joystick	•	•	•	•	•
Joystick steering	•		•		
Cab elevation, hydraulic (LHC)	•	•	•	•	•
Cab elevation, hydraulic with double parallelogram (LHC-D)	+	+	+	+	+
Cab elevation, rigid (LFC)	+	+	+	+	+
Automatic air conditioning	•	•	•	•	•
Wheel steering (slim version)	+		+		
LiDAT, vehicle fleet management	•	•	•	•	•
Engine shut-down (emergency stop) cab ²⁾		•	•	•	•
Proportional control	•	•	•	•	•
Radio Comfort, control via display with handsfree set	+	+	+	+	+
Preparation for radio installation	•	•	•	•	•
Back-up alarm (acoustic signal is emitted traveling backward, can not be switched off)	+		+		
Amber beacon, on cabin, LED double flash	+	+	+	+	+
Windows made from impact-resistant laminated safety glass	•	•	•	•	•
Windscreen wiper, roof	+	+	+	+	+
Windshield wiper, entire windscreen	•	•	•	•	•
Top guard	+	+	+	+	+
Front guard, adjustable	+	+	+	+	+
Sun visor	+	+	+	+	+
Stationary air-conditioning ²⁾		•	•	•	•
Left control console, folding	•	•	•	•	•



Equipment

	110 M	110 C	110 M HR	110 C HR	110 C Gantry
Boom lights, 2 pieces, LED	•	•	•	•	•
Stick lights, 4 pieces, LED	•	•	•	•	•
Boom shutoff (retract/extend), electronically	+	+	+	+	+
Equipment with electro-hydraulic end position control	•	•	•	•	•
AutoLift	+	+	+	+	+
Pressure warning mechanism hoist cylinder	•	•	•	•	•
ERC system	•	•	•	•	•
Filter system for attachment	+	+	+	+	+
Boom cylinder cushioning	•	•	•	•	•
Stick camera (with separate monitor), bottom side, with protection	+	+	+	+	+
Load torque limitation	+	+	+	+	+
Liebherr multi coupling system	+	+	+	+	+
Pipe fracture safety valves hoist cylinders	•	•	•	•	•
Pipe fracture safety valves stick cylinders	•	•	•	•	•
Quick coupling system MH 110B	+	+	+	+	+
Protection for piston rod, energy recovering cylinder	+	+	+	+	+
Protection for piston rods, hoist cylinder	+	+	+	+	+
Stick shutoff (retract), electronically	•	•	•	•	•
Stick shutoff (retract/extend), electronically	+	+	+	+	+
Retract stick without pressure	•	•	•	•	•
Sticks with quick coupling	+	+	+	+	+
Overload warning device	+	+	+	+	+



Complete Machine

	110 M	110 C	110 M HR	110 C HR	110 C Gantry
Lubrication					
Lubrication undercarriage, manually – centralised (one grease point)	•		•		
Central lubrication system for uppercarriage and equipment, automatically	•	•	•	•	•
Central lubrication system for undercarriage, automatically	+		+		
Central lubrication system, extension for attachment	+	+	+	+	+
Special coating					
Special coating, variants	+	+	+	+	+
Monitoring					
Rear view monitoring with camera	•	•	•	•	•
Side view monitoring with camera	•	•	•	•	•

• = Standard, + = Option

* = country-dependent, ¹⁾ not with electric drive, ²⁾ only with electric drive

Options and/or special equipments, supplied by vendors other than Liebherr, are only to be installed with the knowledge and approval of Liebherr in order to retain warranty.

The Liebherr Group of Companies



Wide Product Range

The Liebherr Group is one of the largest construction equipment manufacturers in the world. Liebherr's high-value products and services enjoy a high reputation in many other fields. The wide range includes domestic appliances, aerospace and transportation systems, machine tools and maritime cranes.

Exceptional Customer Benefit

Every product line provides a complete range of models in many different versions. With both their technical excellence and acknowledged quality, Liebherr products offer a maximum of customer benefits in practical applications.

State-of-the-art Technology

To provide consistent, top quality products, Liebherr attaches great importance to each product area, its components and core technologies. Important modules and components are developed and manufactured in-house, for instance the entire drive and control technology for construction equipment.

Worldwide and Independent

Hans Liebherr founded the Liebherr family company in 1949. Since then, the family business has steadily grown to a group of more than 130 companies with more than 46,000 employees located on all continents. The corporate headquarters of the Group is Liebherr-International AG in Bulle, Switzerland. The Liebherr family is the sole owner of the company.

www.liebherr.com